

Upmatic® 3006

english

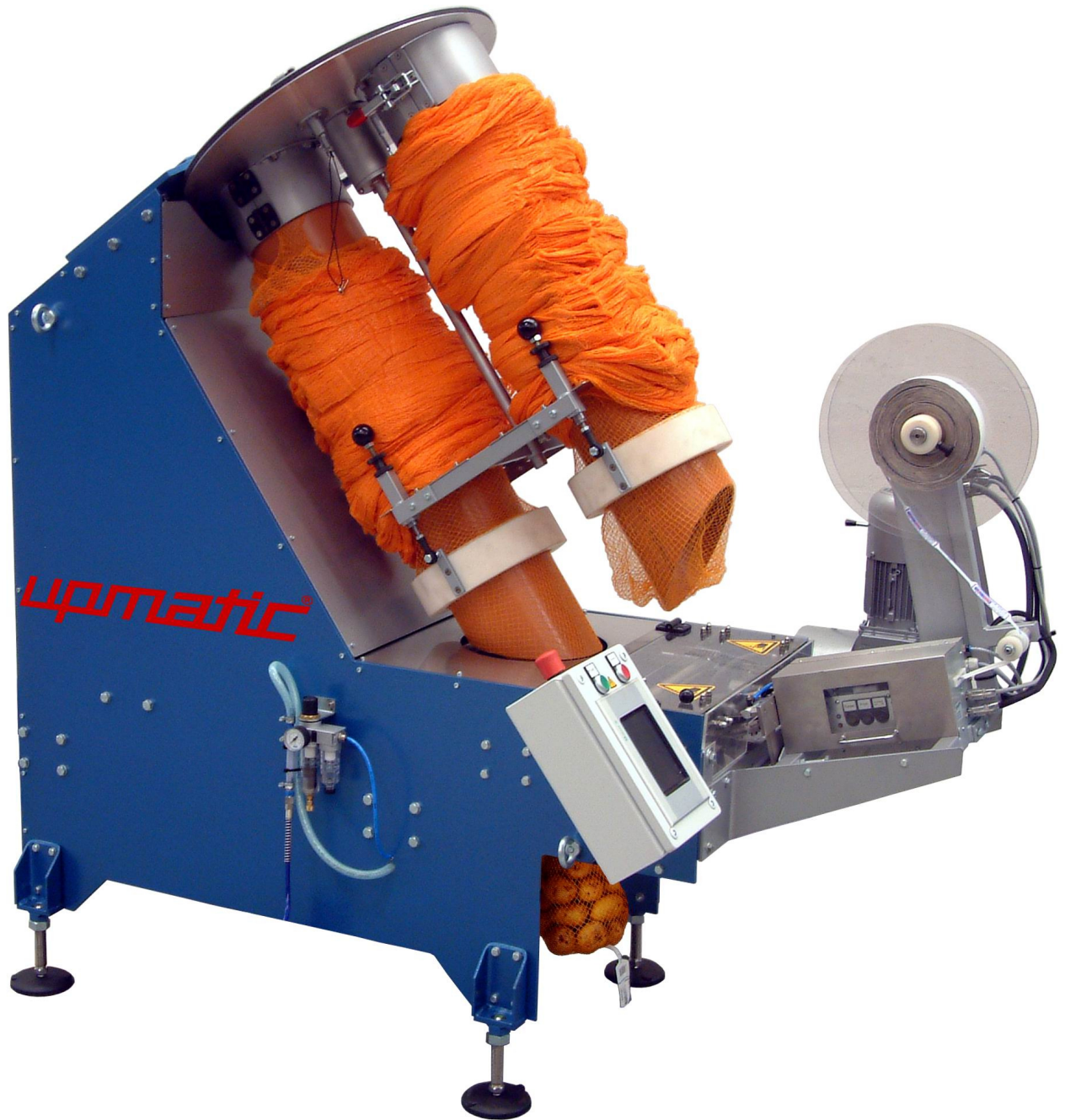

Upmatic typ 3006 = full automatic double tube net clipper for filling weights from 0,5 kg up to 5 kgs. Suitable for all fine and coarse products in the food and non-food industries.

The Upmatic 3006 is extremely rugged and easy to operate. The continuous net is pulled from the tube pneumatically, clipped together at the bottom, filled with goods, clipped together at the top and labelled at the same time. The entire process is completely automatic and allows extremely high cycles.

As soon as the net has been processed on one of the tubes, the automatic clipper interrupts the process for a moment, swings the other tube into the working position and continues the filling and closing operation – everything being done completely automatically. While the machine works, the empty tube can be refilled with net.

The Upmatic 3006 is equipped with level grubs for height adjustment. Combination with all common weighing and dosing equipment is possible.

In our customers' interest, we reserve right to introduce technical changes.

Upmatic® 3006

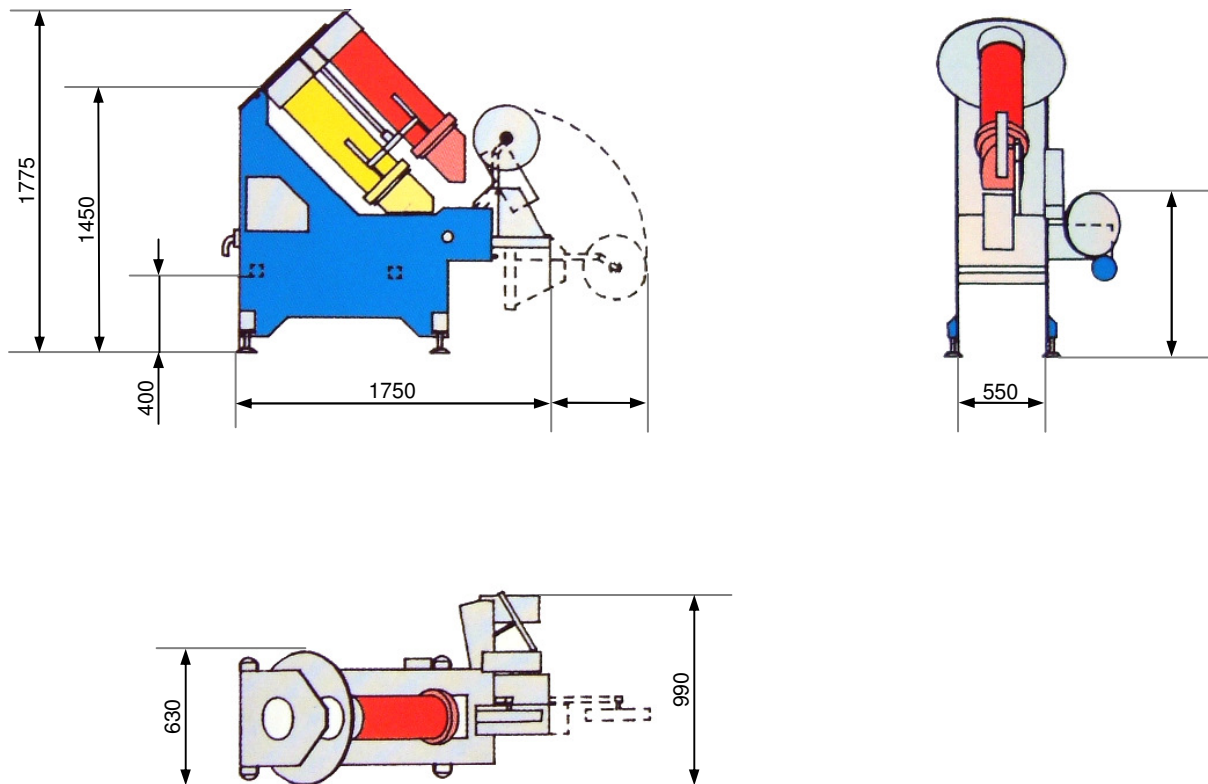

Maschinentypen:

Upmatic 3006: standard model with double tube.
See illustrations and explanatory text.

Upmatic 3005: standard model with single tube.

Accessories:

- packing transport belt in individual sizes
- turntable
- pneumatic bag holder
- marking equipment: - thermo printing system for wineglass labels, and with stub strip device
- holder for pre-printed label band

Technical Data:

- capacity: max. 40 cycles/min.
The capacity depends on type of weigher, its position and on the filling weight.
- supply voltage: 3 x 400 V + N + PE
- power consumption : 3,0 kW
- air pressure: 6 bar
- air consumption : 1,5 m³ / h
- weight: 450 kgs